

This pole mount metering cabinet has a service entrance rated main breaker panel and an electrical device compartment below. This panel can be fed from the top or the bottom and up to 100A single phase.

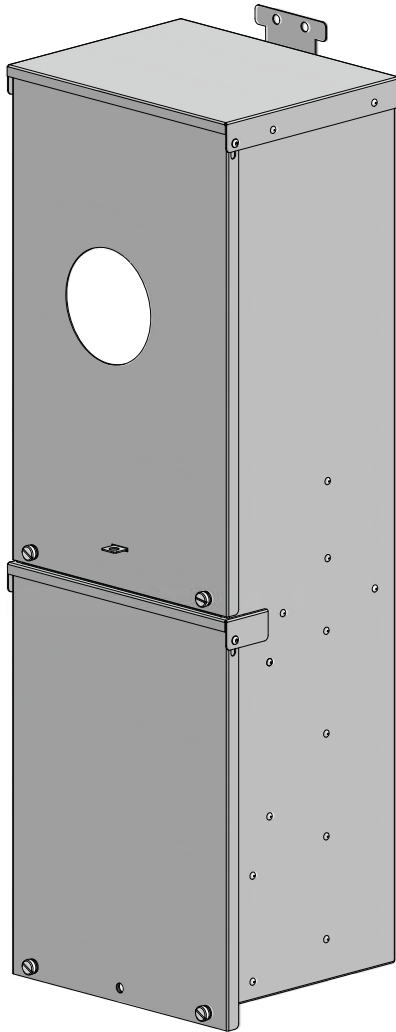

Features

- 304 (#4) stainless steel construction
- Padlockable covers
- NEMA 3R rated
- Service entrance rated
- Up to 100 amp services with 12 cct single phase panel
- Meter base included
- All mounting hardware included
- Overhead and underground feed
- Pole bracket designed for bolt or band-on installation
- Contactors and controls section for up to two 4 pole contactors/flashers

Specifications

- 125/250 VAC 1 phase
- 10,000 AIR
- ETL certified to applicable CSA and UL standards
- MOTBC approved
- Up to 100 amp main breakers

Optional Components

- Snowplow debris shield
- Aluminum construction
- Meter viewing window
- Up to 22 kAIC rated breakers

Benefits

This all-in-one cabinet makes it easier and faster in the field for installation and also offers additional security for the meter. It has a 200A jumbo meter base and a 12 cct breaker panel. There is a 2" pole access hole in the back of the control devices compartment, and the cabinet can be either bolted or banded to the pole. All the required field mounting hardware including bullet hub, chase nipple, sealing rings and installation instructions are included.



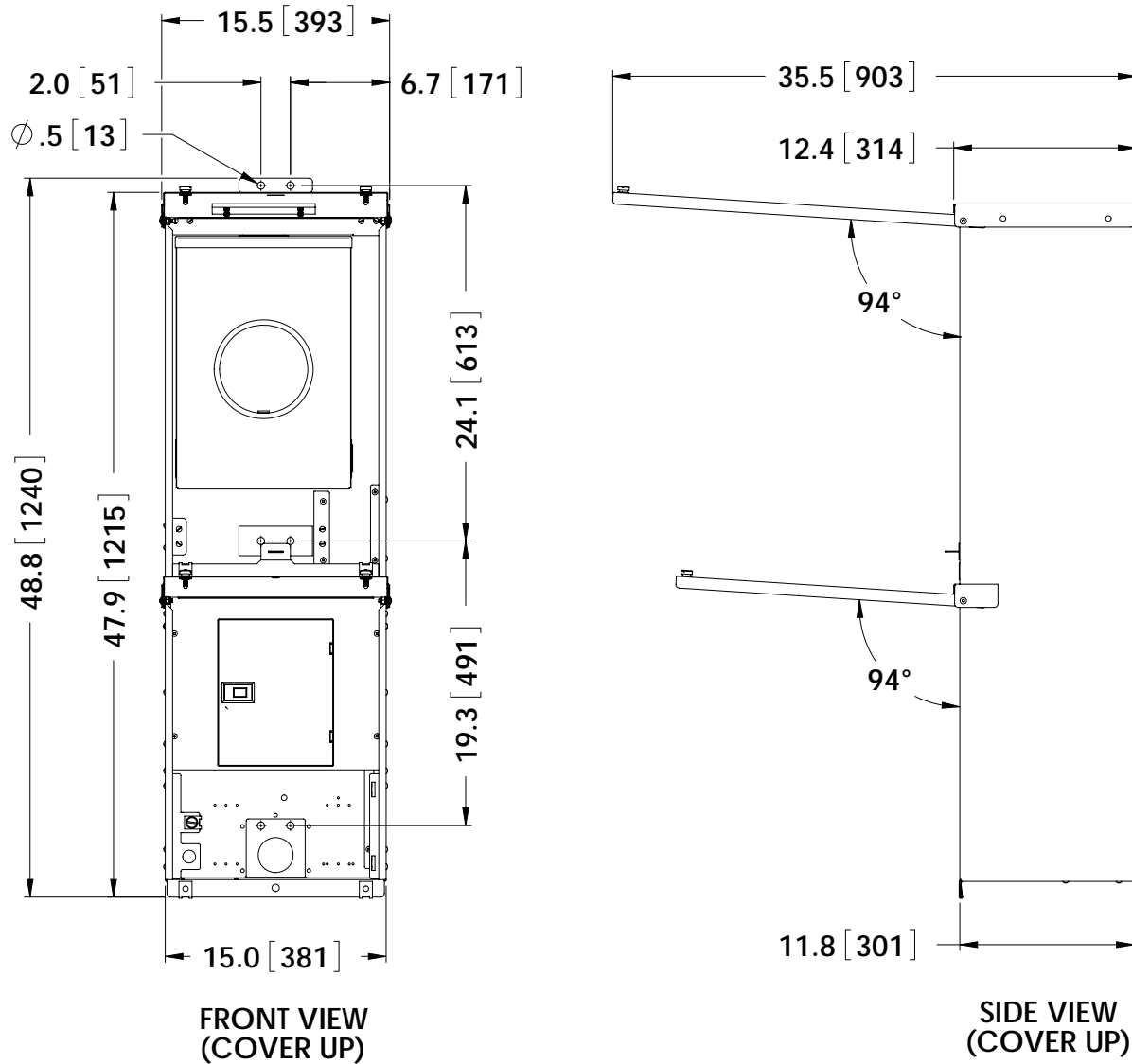

PART NUMBER	HEIGHT	WIDTH	DEPTH	VIEWING WINDOW	MAIN BREAKER
HWYSMC8A-3N	48"	15.5"	12"	NONE	30A
HWYSMC8A-3W	48"	15.5"	12"	YES	30A
HWYSMC8A-6N	48"	15.5"	12"	NONE	60A
HWYSMC8A-6W	48"	15.5"	12"	YES	60A
HWYSMC8A-10N	48"	15.5"	12"	NONE	100A
HWYSMC8A-10W	48"	15.5"	12"	YES	100A

ADDITIONAL OPTIONS
CROSSWALK FLASHER
WARNING BOARD FLASHER
LIGHTING CONTACTOR (QTY 1)
LIGHTING CONTACTOR (QTY 2)

CONSULT FACTORY FOR ALL OPTIONAL CONFIGURATIONS