

For extreme environments where corrosion protection is required, Valid Manufacturing produces a full range of custom NEMA 4X cabinets in multiple sizes, configurations, closures and hinge assemblies. Our custom capabilities allow us to design and build the enclosure to your specifications.

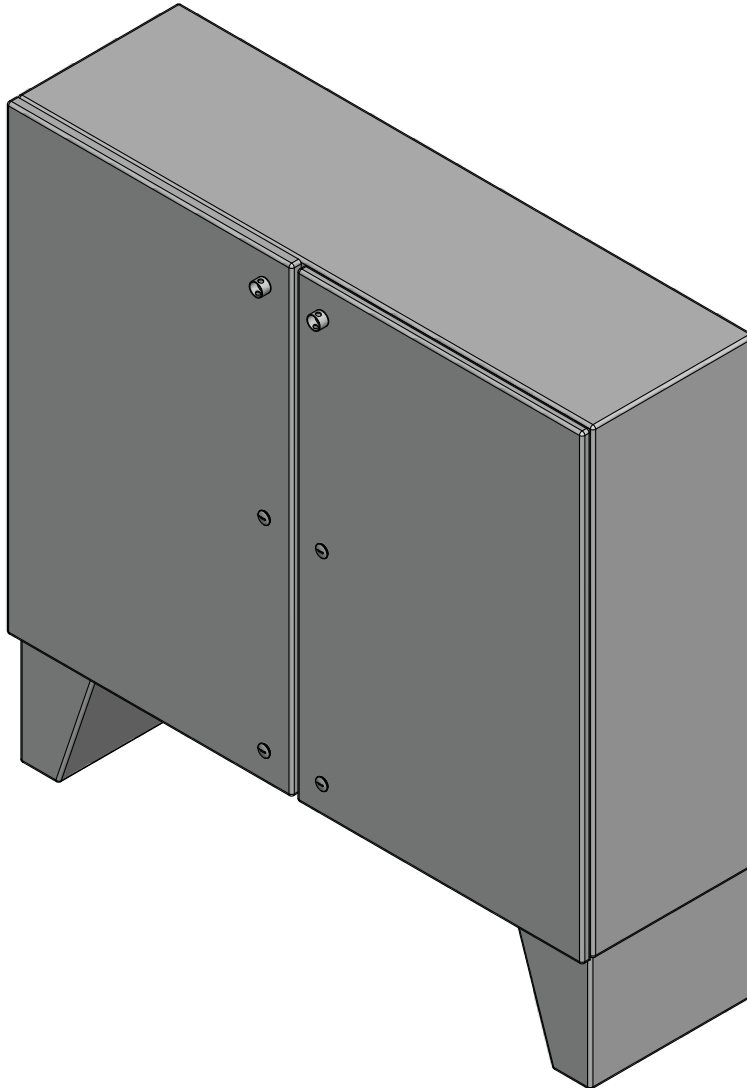

Features

- 304 (#4) stainless or marine-grade aluminum construction
- NEMA 4X rated
- Multiple handle configurations
- Full backpan
- Wall mount or free standing

Specifications

- ETL certified to applicable CSA and UL standards

Optional Components

- Heater and thermostat
- Fan and thermostat
- Lights and door switch
- Styrofoam insulation
- Shelves
- Side panels
- Security handle cover
- Electrical controls/power distribution
- Pre punched backpan
- Custom powder coat colours

Benefits

This is one example of the style of enclosure available in our NEMA 4X family. Multiple sizes and configurations, including all required internal components, can be produced to suit your specific application.